

---

# LCPN

---

CONCRETE POOL NICHE  
0640EQ

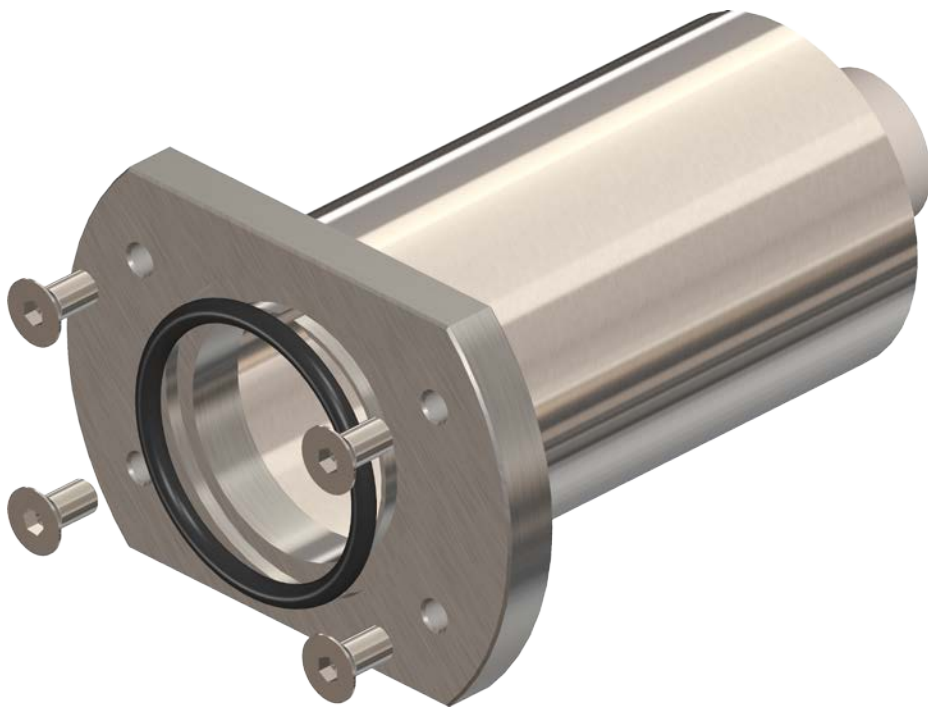

Installation Instructions

---

**ASTEL**  
LIGHTING

## PREFACE

The Concrete Pool Niche LCPN0640EQ is designed to install the METEOR EQ series of underwater lights on the ceramic tile-finish pools.

The LCPN0640EQ niche is made of electropolished stainless steel. The O-ring and stainless steel screws together with stainless body enable reliable waterproof and esthetical installation.

## FEATURES

- For using with METEOR EQ series
- Electropolished Stainless Steel Body
- Stainless Steel Screws
- Simple Installation

## COMPONENTS

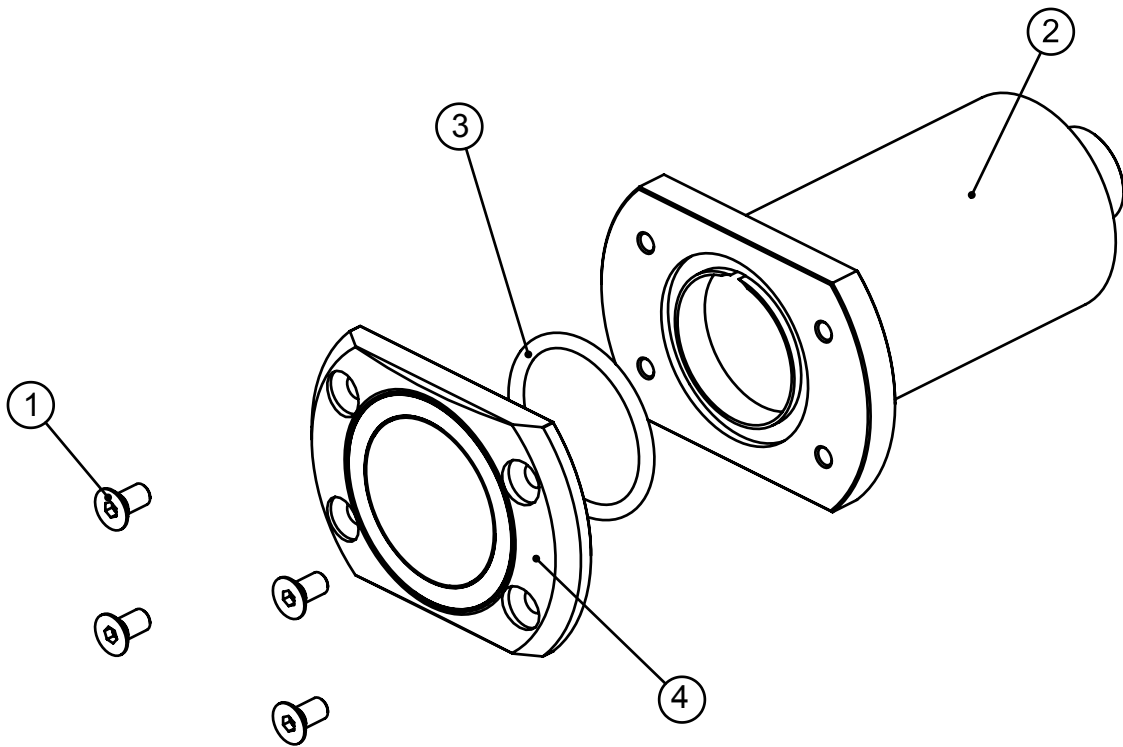

### (1) SCREWS

Stainless steel screws for underwater light fixing.

### (2) NICHE

Stainless steel body.

### (3) O-RING

Outer O-ring.

### (4) UNDERWATER LIGHT

The METEOR EQ series of underwater lights.

# INSTALLATION

The LCPN0640EQ kit consists of the following components:

- Stainless steel body
- 4 x fixing screw M6 X 20
- 1 x O-ring
- Installation instructions

## Fixing and sealing

The LCPN0640EQ niche has to be mounted inside the concrete wall of the pool with ceramic tile finish under water line.

The METEOR EQ series of underwater lights has to be fixed to the LCPN0640EQ niche with 4 screws. The sealing is enabled by the help of O-ring which have to be inserted properly.

The installation has to be realized by a qualified personnel.

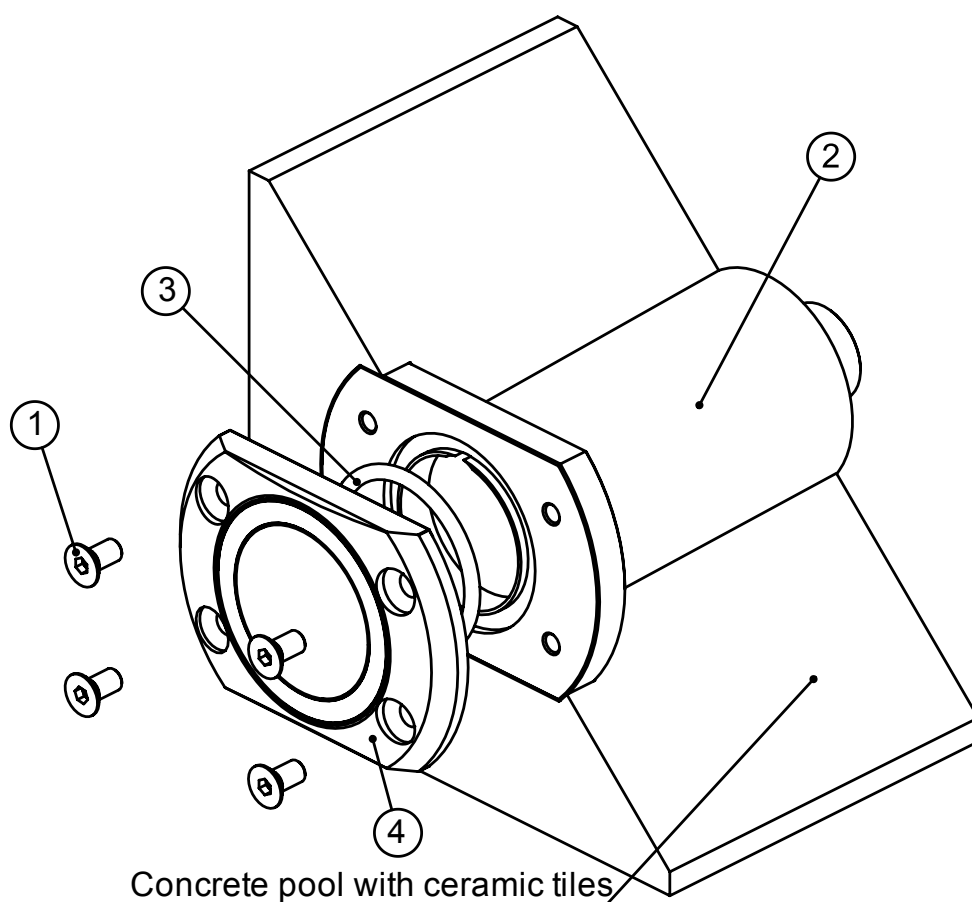

## **Note:**

- ***Do not overtighten the screws as this can result in underwater pool light or niche damage.***

# TECHNICAL SPECIFICATIONS

Material  
Dimensions  
Weight

Electropolished stainless steel (SAE316L)  
99 x 69 x 130 mm  
1 kg

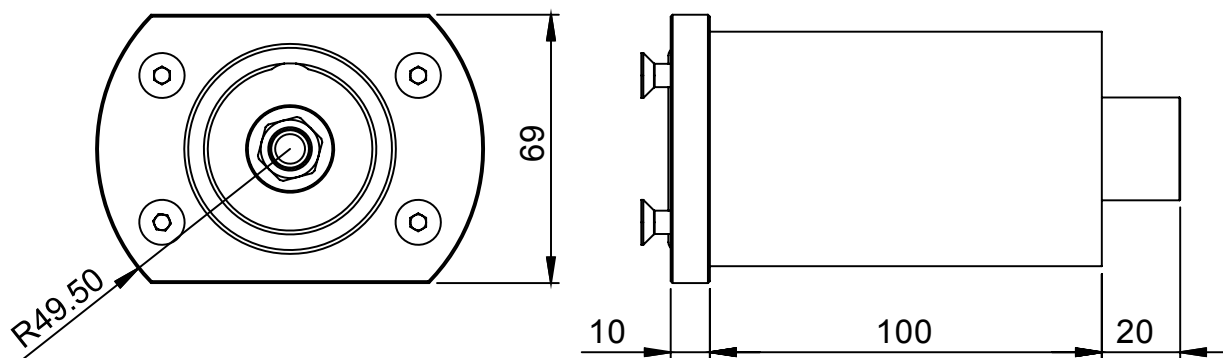

*Design and specifications subject to change without notice.*

**ASTEL d.o.o., Dutovlje 138, 6221 Dutovlje, Slovenia**

**Tel: +386 5 7310771, +386 5 7310772**

**Fax: +386 5 7310789**

**E-mail: [info@astel-lighting.com](mailto:info@astel-lighting.com)**

**Web: [www.astel-lighting.com](http://www.astel-lighting.com)**